

HASEL

BAĞLANTI ELEMANLARI

haselbaglanti.com.tr



ÜRÜN KATALOĞU



<u>ÜRÜN KODU</u>	<u>YAYLI PİM</u>	<u>1 ÇUVAL (Adet)</u>
HS001	6 mm Yaylı Pim	1.000
HS002	8 mm Yaylı Pim	1.000
HS003	9 mm Yaylı Pim	1.000
HS004	10 mm Yaylı Pim	1.000

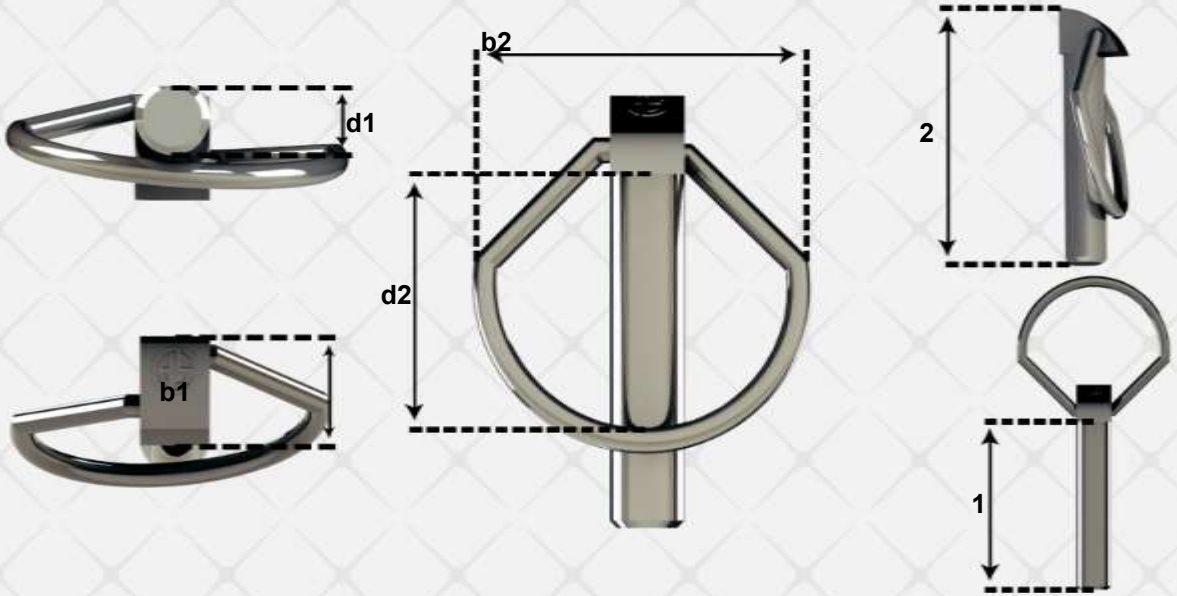

YAYLI PİM ÖLÇÜLERİ

<u>Cinsi</u>	<u>d1(mm)</u>	<u>d2</u>	<u>i1</u>	<u>i2</u>	<u>b1</u>	<u>b2</u>
6 mm	6	32	46	56	12.5	45
8 mm	7.8	32	46	57	12.5	45
9 mm	8.8	32	46	57	12.5	45
10 mm	9.5	32	46	57	14	45

ÜRÜN KODU	GOLD YAN GERĞİ PİMLERİ	1 ÇUVAL (Adet)
HS005	6 mm MF Gold Yan Gerği Pimi	500
HS006	8 mm MF Gold Yan Gerği Pimi	500
HS007	10 mm MF Gold Yan Gerği Pimi	500

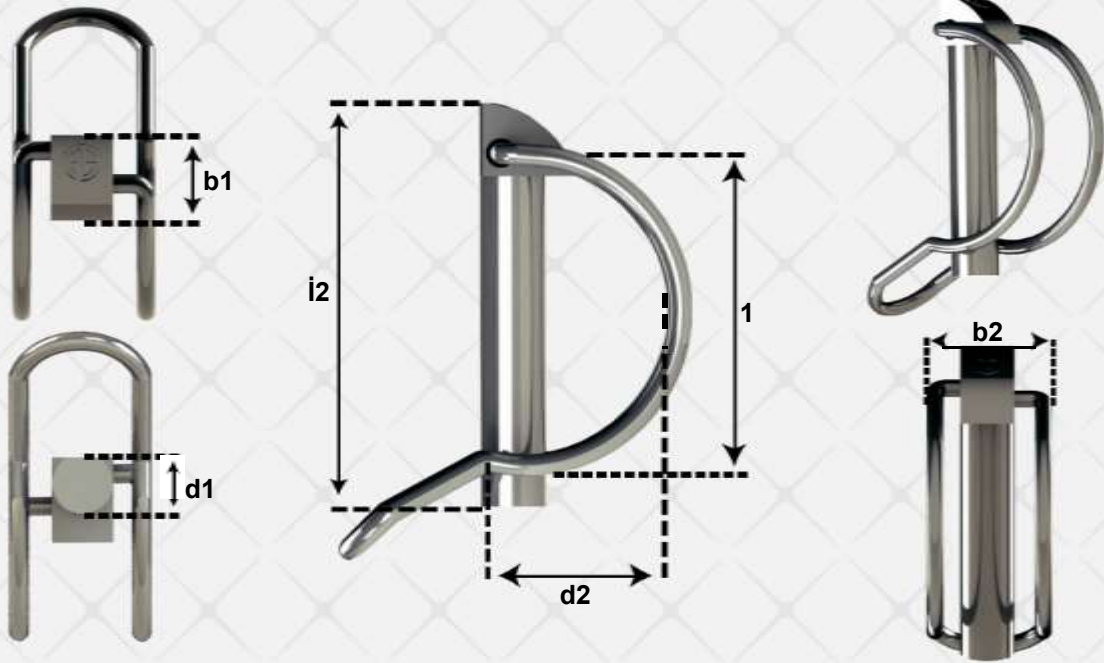
GOLD YAN GERĞİ PİM ÖLÇÜLERİ

Cinsi	d1(mm)	d2	i1	i2	b1	b2
6X46	6	32	46	56	12.5	16
8X65	7.8	42	46	56	12.5	18
10X65	9.6	42	46	57	14	18



ÜRÜN KODU	YAN GERĞİ PİMLERİ	1 ÇUVAL (Adet)
HS008	12 mm Yan Gerği Pimi (80/66)	200
HS009	14 mm Yan Gerği Pimi (80/66)	200
HS010	16 mm Yan Gerği Pimi (80/66)	200

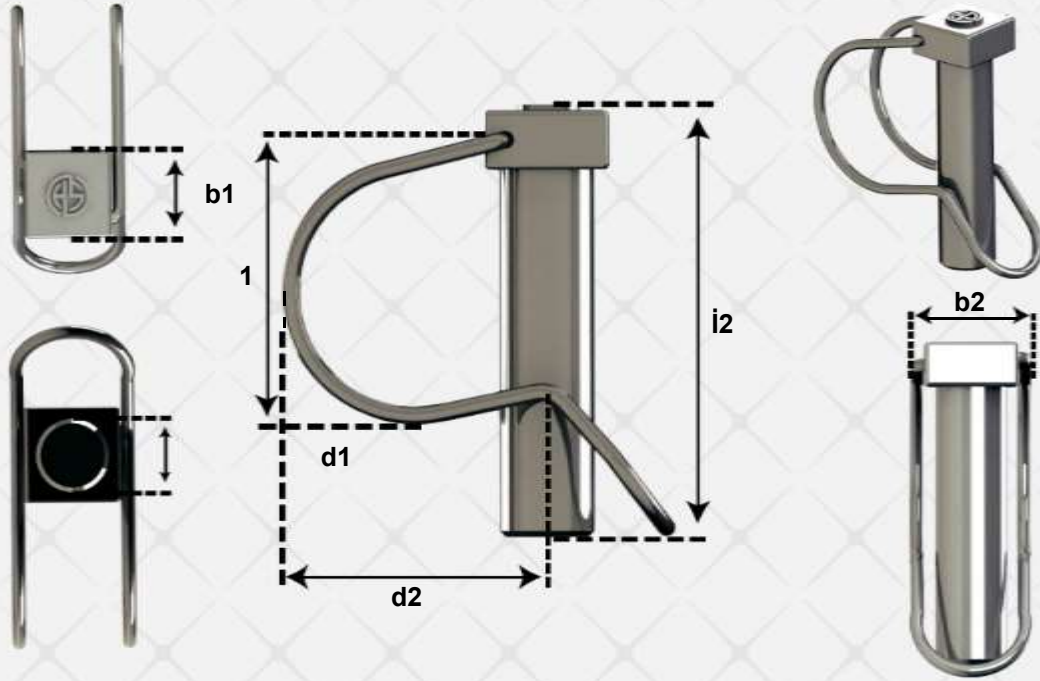

YAN GERĞİ PİM ÖLÇÜLERİ

Cinsi	d1(mm)	d2	i1	i2	b1	b2
12 mm	12	42	60	73	17	26
14 mm	14	42	60	74	19	26
16 mm	16	42	60	74	20	27

ÜRÜN KODU	R FİRKETE PİMLERİ	1 ÇUVAL (Adet)
HS011	2 mm R Firkete Pimi	10.000
HS012	3 mm R Firkete Pimi	3.000
HS013	4 mm R Firkete Pimi	2.000
HS014	5 mm R Firkete Pimi	1.000
HS015	6 mm R Firkete Pimi	500
HS016	8 mm R Firkete Pimi	500

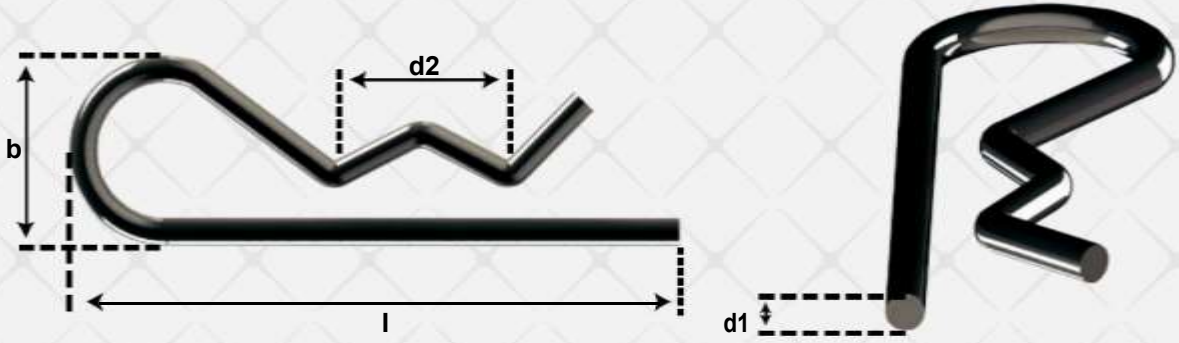

R FİRKETE PİM ÖLÇÜLERİ

Cinsi	d1(mm)	l	b	d2
2 mm R	2	47	14	10-15.
3 mm R	3	72	22	10-15.
4 mm R	4	82	27	15-20.
5 mm R	5	94	32	18-23.
6 mm R	6	94	30	20-25.
8 mm R	7	96	32	25-35.



ÜRÜN KODU	YARIM YUVARLAK FİRKETE PİMİ	
HS017	5 mm Yarım Yuvarlak Firkete Pimi	1.600

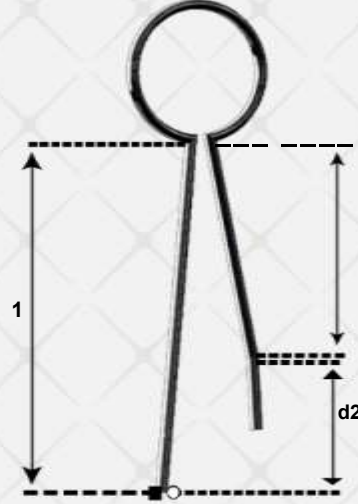

YARIM YUVARLAK FİRKETE PİM ÖLÇÜLERİ

Cinsi	d1(mm)	i1	b	d2	i2
5 mm Y.Y.	2.5	80	24	6	25

ÜRÜN KODU	YAYSIZ ÇAPA MAKİNASI PİMLERİ	1 ÇUVAL (Adet)
HS018	8 mm Kısa Yaysız Çapa Pimi (B'si 54)	1.000
HS019	8 mm Uzun Yaysız Çapa Pimi (B'si 70)	1.000

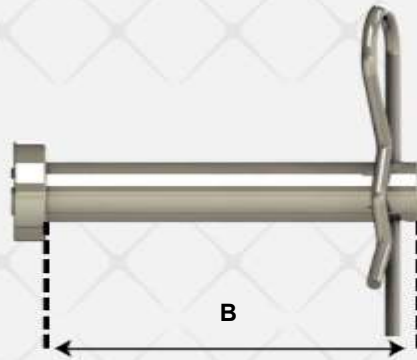

YAYSIZ ÇAPA MAKİNASI PİMİ ÖLÇÜLERİ

Cinsi	A	B	F
8 mm Kısa	7.8	54	15
8 mm Uzun	7.8	70	15

ÜRÜN KODU	ÇAPA MAKİNASI PİMLERİ	1 ÇUVAL (Adet)
HS020	8 mm Kısa Çapa Makinası Pimi (B'si 44)	1.000
HS021	8 mm Orta Çapa Makinası Pimi (B'si 54)	1.000
HS022	8 mm Uzun Çapa Makinası Pimi (B'si 70)	500
HS023	10 mm Kısa Çapa Makinası Pimi (B'si 54)	1.000
HS024	10 mm Uzun Çapa Makinası Pimi (B'si 70)	500

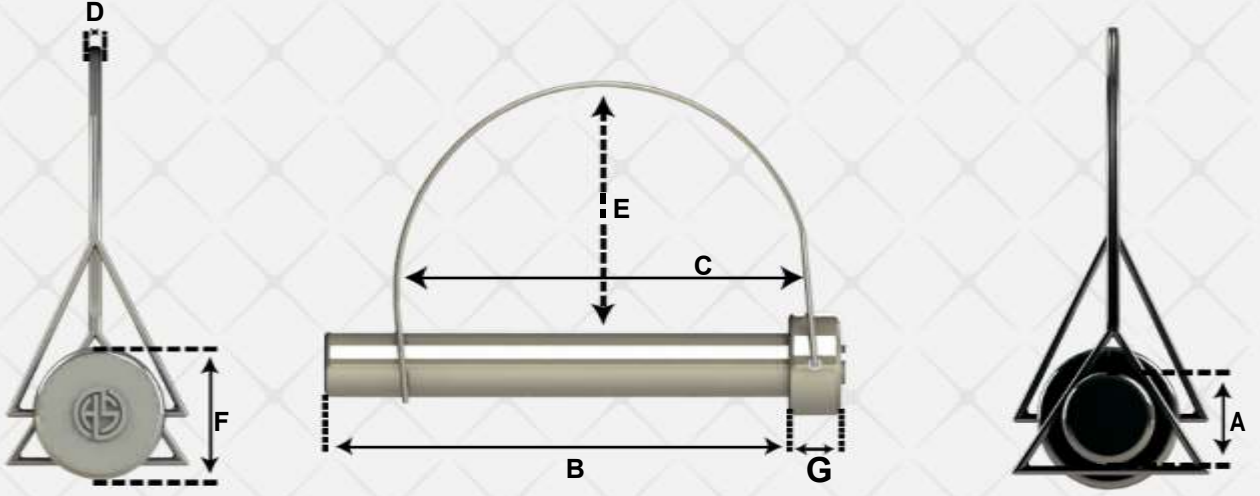

ÇAPA MAKİNASI PİMİ ÖLÇÜLERİ

Cinsi	D	B	F	G	A	C	E
8 mm Kısa	2	44	15	7	7.8	35	23
8 mm Orta	2	54	15	7	7.8	45	35
8 mm Uzun	2	70	15	7	9.8	50	40
10 mm Kısa	2	54	15	7	9.8	50	35
10 mm Uzun	2	70	15	7	9.8	50	40



HASEL

BAĞLANTI ELEMANLARI

YOZGAT ORGANİZE

SANAYİ BÖLGESİ

1. CAD. 2. SOK NO:15 YOZGAT/YERKÖY

info@haselbaglanti.com.tr

www.haselbaglanti.com.tr

0552 666 90 66

0354 217 90 66

